

# PRODUCT SPECIFICATION SHEET



## General Characteristics

Brand : LinkedPro  
Code : SCH19X13.5  
Description : Shelf Rack, 2 Units

## Physical Characteristics

Material : Rolled steel sheet  
AWG : 16  
Color : Black  
Application : Interior

## Electrical Characteristics

Input Voltage : NA  
Output Voltage : NA  
Consumption : NA

## Dimensional Characteristics

Width : 19 in (481 mm)  
Height : 3.5 in (88 mm)  
Depth : 13.5 in (348 mm)  
Weight : 5.16 lbs (2.34 Kg)  
Max suggested load: 44 lbs (20 Kg)

## Special Characteristics:

Electrostatic powder paint

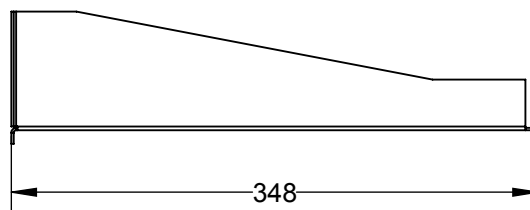
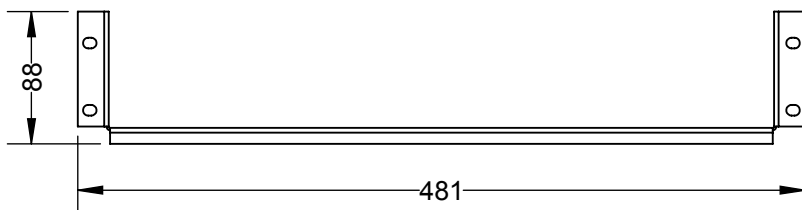
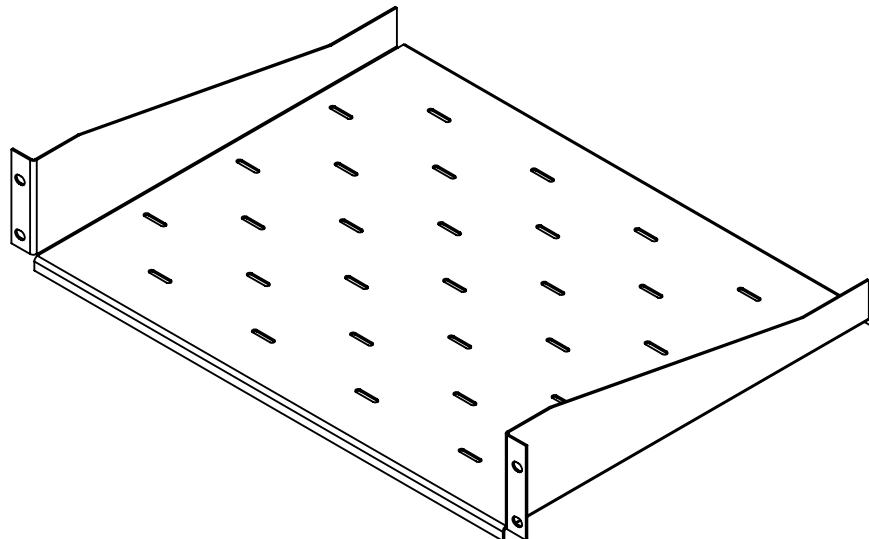

**epcom**

+1(915)533-5119 | [engineering@epcom.net](mailto:engineering@epcom.net)  
1630 E Paisano Dr, El Paso, Texas, United States of America