

M5T

5MP Turret Dome IP POE Weatherproof Security Camera W/ 2.8mm Fixed Lens



PRODUCT HIGHLIGHTS

Up to 5MP HD Resolution

2.8mm Fixed Lens

1/2.7" Progressive CMOS Image Sensor

Field of View: 92°

Up to 30m IR range

H.265 / H.264 Video Compression

IP66 Weatherproof Protection

DC12V or POE Power



PRODUCT DIMENSIONS

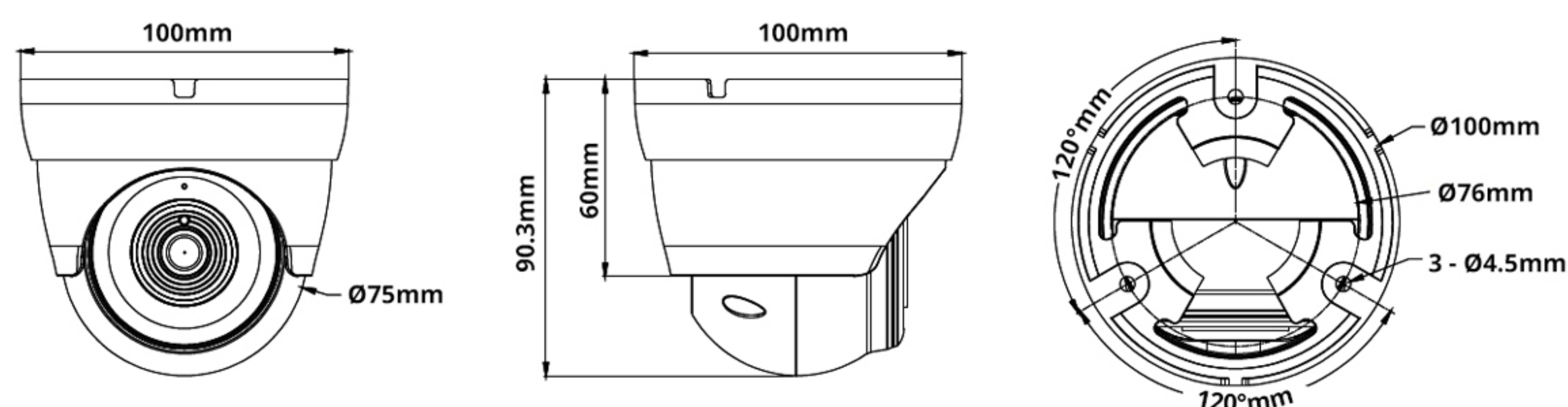

PRODUCT SPECIFICATIONS

Product Model	M5T
Highest Resolution	5MP 2592(H)×1944(V)
Image Sensor	1/2.7" Progressive CMOS
Min. Illumination	Color 0.1lux @ F1.2(AGC ON) ; B/W 0 lux @ IR ON
Shutter	1/5 ~ 1/20000s
Lens	2.8 mm H.FOV: 92°
F No.	F 2.0 ±5%
WDR	Digital WDR
Video Compression	H.265 / H.264
Video Bit Rate	8Kbps ~ 8Mbps
Resolution	Dual Streams Supported: Main Stream (1-30fps) 5MP @ 1-15fps (2592×1944), 4MP @ 1-25fps (2592×1520), 3MP (2048×1520), (2304×1296), 1080P @ 30fps (1920×1080), 960P (1280×960), 720P (1280×720) Sub Stream VGA (640×480), QVGA (320×240)
Image Controls	Flip, Rotation, Corridor Mode, Saturation, Brightness, Contrast, Hue, Sharpness Adjustable
Day & Night	IR cut filter with auto switch (Day/Night/Auto/Schedule)
System Compatibility	ONVIF (v2.6)
Interface	RJ45 10M / 100M Ethernet interface
IR LED Range	Up to 30m
Weatherproof Rating	IP66
Power Supply	DC12V or POE
Consumption	≤ 7W
Dimensions	Ø100x90.3mm
Weight	~0.8 lbs
Operating Temperature	-22°F ~ +131°F